

# LL15.70

**MAX. KORBTRAGLAST 230 KG**

(2 Personen 80x2=160 kg + Werkzeugkasten70 kg)

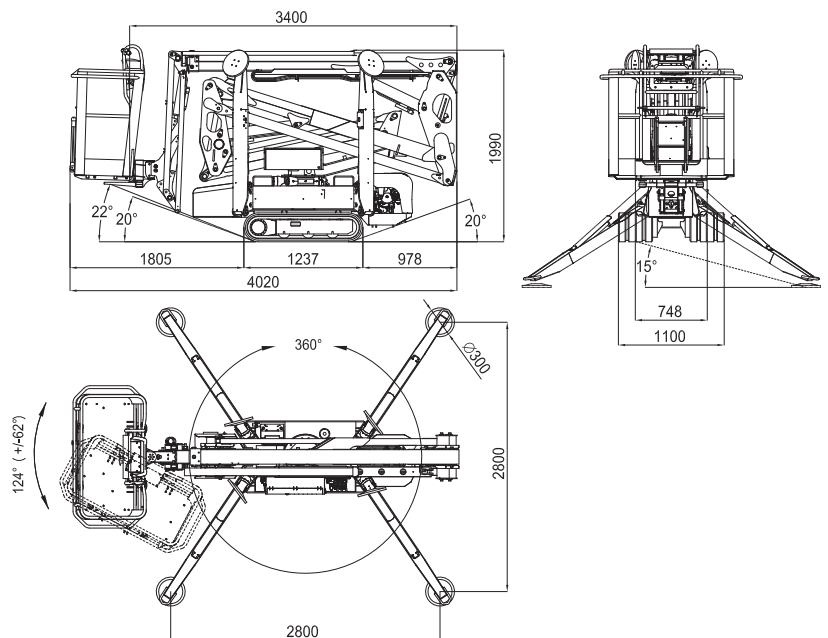
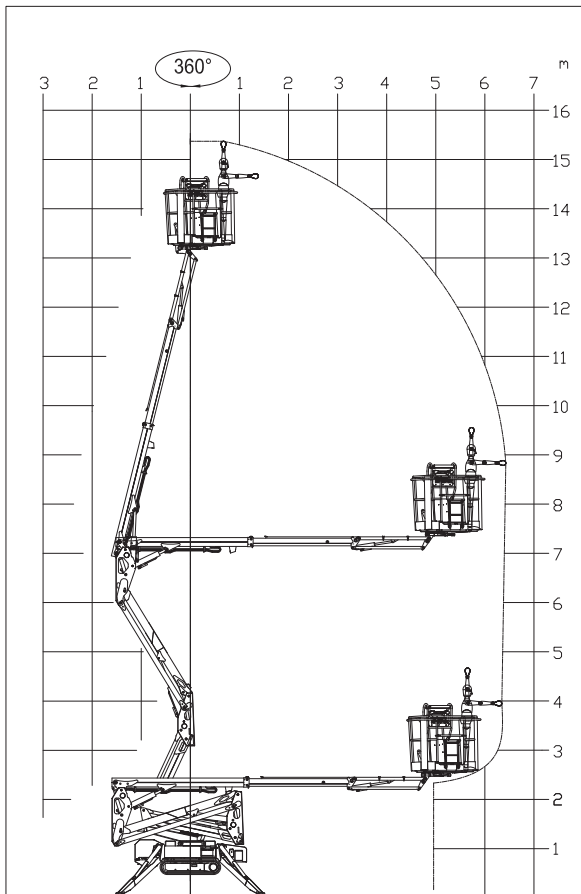

15,40 m



1.335 x 690 x h. 1.100 mm



2.800 x 2.800 mm



6,60 m



124° (+/-62°)



IIIS – Abstütz- und Einfahrautomatik  
serienmässig



4,02 m



16° / 28,7%



Kabelfernbedienung



3,40 m



748 - 1.100 mm



GPRS-GPS



1,99 m



1.670 daN - 2,36 daN/cm<sup>2</sup>



R.A.H.M.



Elektromotor mit Lithium-Batterien  
3,6 kWh  
Optional



#### BENZINMOTOR

Hersteller ..... HONDA  
 Modell ..... GX390  
 Zylinder und Hubraum .....  
 ..... einzylindrig 389 cm<sup>3</sup>  
 Max. Bruttoleistung .....  
 ..... 11,7 PS - 8,7 kW @ 3600 U/min  
 Elektrischer Anlasser ..... 12 volt

#### DIESELMOTOR

Hersteller ..... HATZ  
 Modell ..... 1B40 - HD Autorev  
 Zylinder und Hubraum .....  
 ..... einzylindrig 462 cm<sup>3</sup>  
 Max. Bruttoleistung .....  
 ..... 10 PS - 7,5 kW @ 3600 U/min  
 Elektrischer Anlasser ..... 12 volt

#### ELEKTROANLAGE - LITHIUM-ION

Lithium Akkupack ..... 3,6 kWh  
 Batterielader an Bord .....  
 ..... 220V 50Hz oder 110V 50Hz  
 Arbeitsautonomie ..... 4-5 h  
 Ladezeit bei komplett leeren Batterien .....  
 ..... 4 h (Schätzwert)  
 Ladezeit bis 80% bei komplett leeren Batterie-  
 rien ..... 2 h (Schätzwert)

#### HYDRAULIKPUMPE

Elektromotor ..... Nr. 2 Zahnradpumpen

#### RAUPENFAHRWERK

Kettenspanner ..... mit Schmierfett  
 Stützrollen pro Seite ..... 3 + Schlitten

Fahrgeschwindigkeit mit 2. Geschwindigkeit Auto2speed:

- Verbrennungsmotor ..... 1,4 - 2,6 km/h  
 - Elektranlage lithium ..... 0,4 - 0,8 - 1,6 km/h

MASCHINENGEWICHT Benzinmotor ..... 1940 kg

MASCHINENGEWICHT Dieselmotor ..... 1960 kg

MASCHINENGEWICHT Elektranlage lithium ..... 1992 kg

MAX. WINDGESCHWINDIGKEIT ..... 12,5 m/s